

# Industrial BLDC Motor

## Features

- High Torque Low Noise
- Minimal Temperature Rise
- High Efficiency
- Hall Effect Sensors
- Customizations Available

## Application

- Industrial / Gear Motor
- Factory Automation



## Dimensions

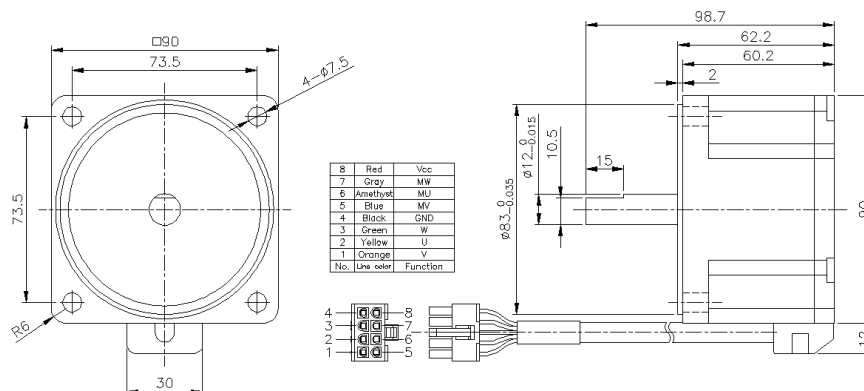

【Above dimensions & below data are for your ref only. For detailed info or customized requirements, you are very welcome to inquire.】

Model No.	Rated Voltage [ V ]	No-Load Speed [ r/min ]	No-Load Current [ mA ]	Rated Torque [ Kg-cm ]	Rated Speed [R.P.M.]	Rated Current [ A ]
ABL009	AC110V	3500	150	4.0	2900	0.8
ABL010	DC24V	2200	700	2.0	1800	2
Model No.	Torque Constant [ Kg-cm/A ]	Max-Efficiency [ % ]	Output [ Watt ]	Number of Pole/Pair	Dimensions [ mm ]	Weight [ g ]
ABL009	4.3	80	120	4	90	1200
ABL010	1.8	70	40	4	90	1200